

# 3gCustomz Rear Diffuser Installation Guide



# 3gCustomz Rear Diffuser Installation Guide

Our Rear Diffusers are meant to install on the bottom of the spare tire wheel well. If you have altered or damaged this area in any way then it is your responsibility to do a test fitment to confirm it will fit.

In Some model specific cases, body plugs may be protruding below the mounting surface. The “feet” or prongs on the body plugs must be flattened out for the diffuser to sit correctly. Please keep an eye out for this during your test fit. Not all makes/model have the body plugs that cause an issue.

Every model and year will have some little differences therefore we strongly recommend that prior to prep and paint you install your Side Splitters and do a test fitment first. Make sure it fits correctly and there no interferences.

Be sure that you have proper clearance on the top, back, sides and bottom and nothing is rubbing.

Use all supplied hardware

While the amount of hardware and mounting location varies by model, these instructions are a general guide for the installation. Pictures may not represent your actual make/model and year.

DISCLAIMER: 3gCustomz LLC cannot control how this product is installed or used. By purchasing this product, the buyer/end user assumes all risks associated with its use and agrees to have the proper skills for its installation. 3gCustomz LLC and its suppliers will not be held responsible, liable or accountable for any injury, damage, loss, penalties, or fines that occur from using this product in any manner.



# 3gCustomz Rear Diffuser Assembly Guide

1. Grab one flat washer and one 10/24" bolt and place from the top of the diffuser.
2. Flip diffuser over and place one fin over exposed bolt.
3. Use one flash wash, wash lock washer and one nut and hand tighten over exposed bolt and fin.
4. Do not tighten until all bolts are installed on all of the fins.
5. Repeat steps 1-4 for all bolts and fins
6. Finally tighten all bolts and continue onto installation on car.



\* We suggest using Loctite on all nuts





# 3gCustomz Rear Diffuser Installation Guide

1. Place diffuser on a jack or find some objects that will allow you to wedge the rear diffuser tightly against the bottom of the spare tire wheel well. Once placed ensure that the diffuser is centered from right to left and in the proper front to back position for your make/model and year.



2. Mark holes with a paint pen or sharpie.



3. Drill pilot hole

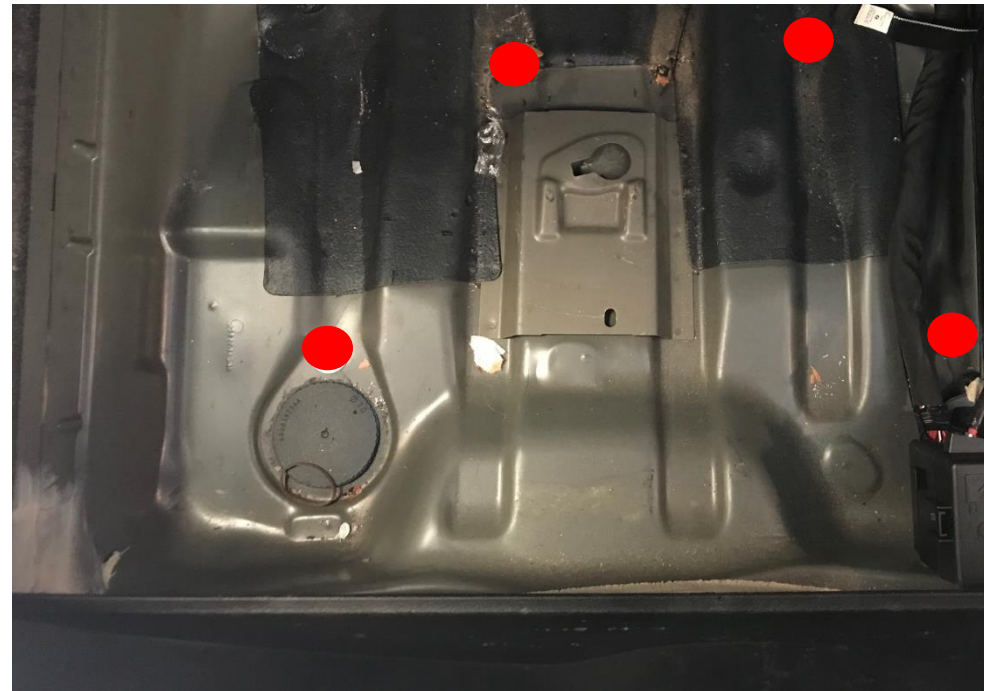

Mounting Holes Locations

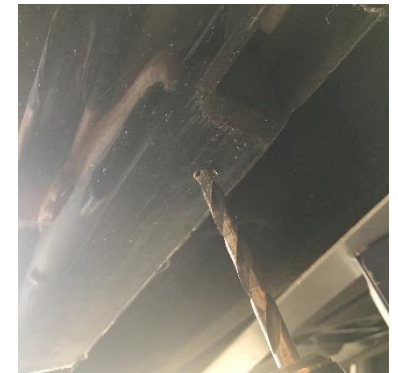

4. Drill 1/4" Hole

# 3gCustomz Rear Diffuser Installation Guide

5. For the rear diffuser to sit flat it requires 2 or more spacers to be used, in 2-4 locations with different sizes. It is imperative that the correct spacer goes in the correct place.

Some Models will vary with spacers.

Please see model specific differences on the last pages

6. Place standard washer on base of bolt, and push bolt from the bottom of the diffuser through the top of the diffuser. Then place the correct spacer on the correct post and use O-Ring/Nylon Washer to hold bolt in place so it does not fall through.

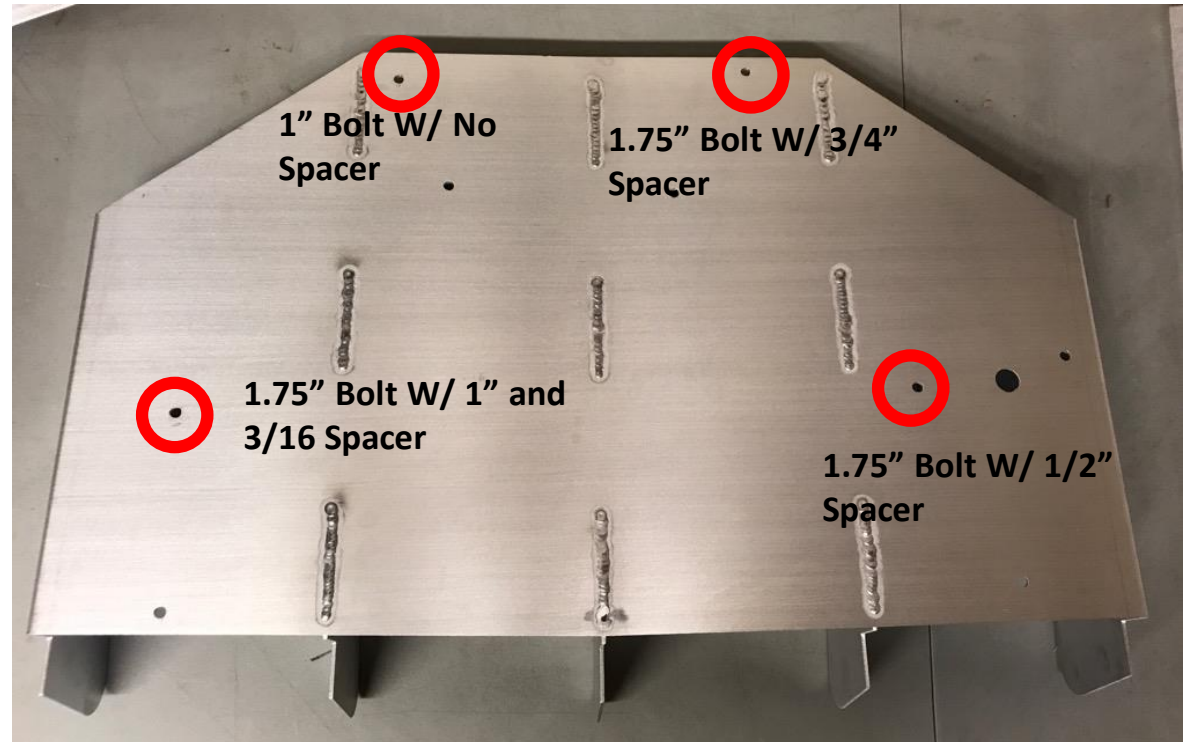

Spacer and Location Guide for:  
2008-2018 Challengers – All Trim  
2005-2018 Chrysler 300 – All Trim

# 3gCustomz Rear Diffuser Installation Guide

7. Slide Diffuser under the car and push bolts through your drilled holes, have someone hold in place or wedge so it is supported tightly against the bottom of the spare tire wheel well.

8. With the bolts protruding through the spare tire wheel well, take a small amount of black silicone sealant and run a bead around the base of the protruding post to cover and bare sheet metal that is exposed due to drilling.

9. Place fender washer on post, then the lock washer and then the nut. Hand tighten all bolts, then finishing tightening once a final centering/alignment has been done.



Installed Bolt with  
Fender and Lock Washer





# 3gCustomz Rear Diffuser Installation Guide

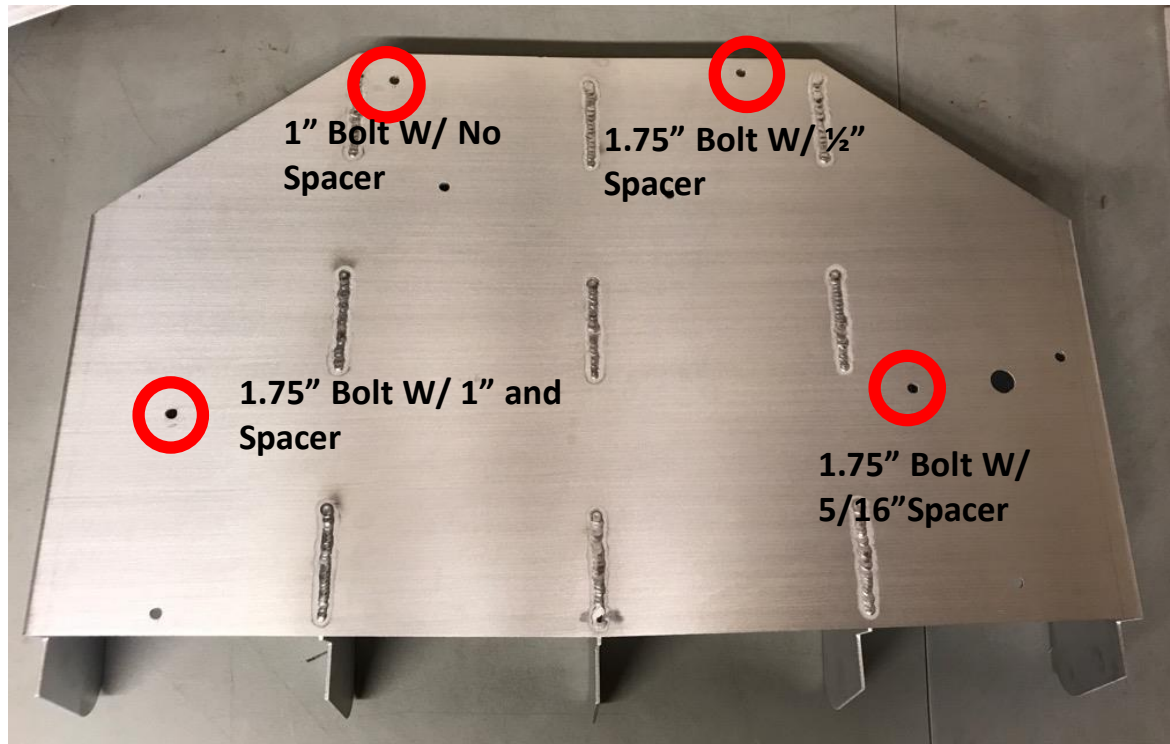

Spacer and Location Guide  
Dodge Charger 2006-2010 – All Trim Levels

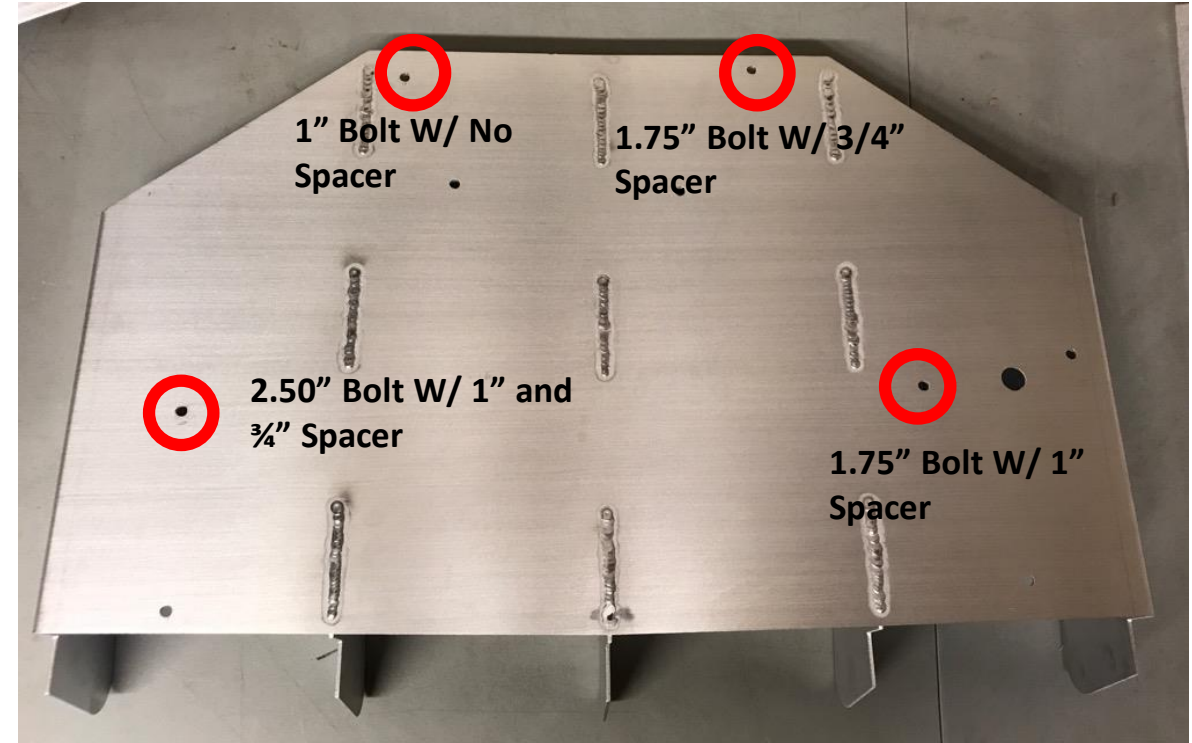

Spacer and Location Guide  
Dodge Charger 2015+ SRT/HellCat/SCAT

\* This model requires the removal of the rear under splash guard. You will then remove 2 OEM speed nuts and place on the 2 tabs. After installing the diffuser, use the 2 OEM screws to attach the diffuser to the bumper lip.



# 3gCustomz Rear Diffuser Installation Guide

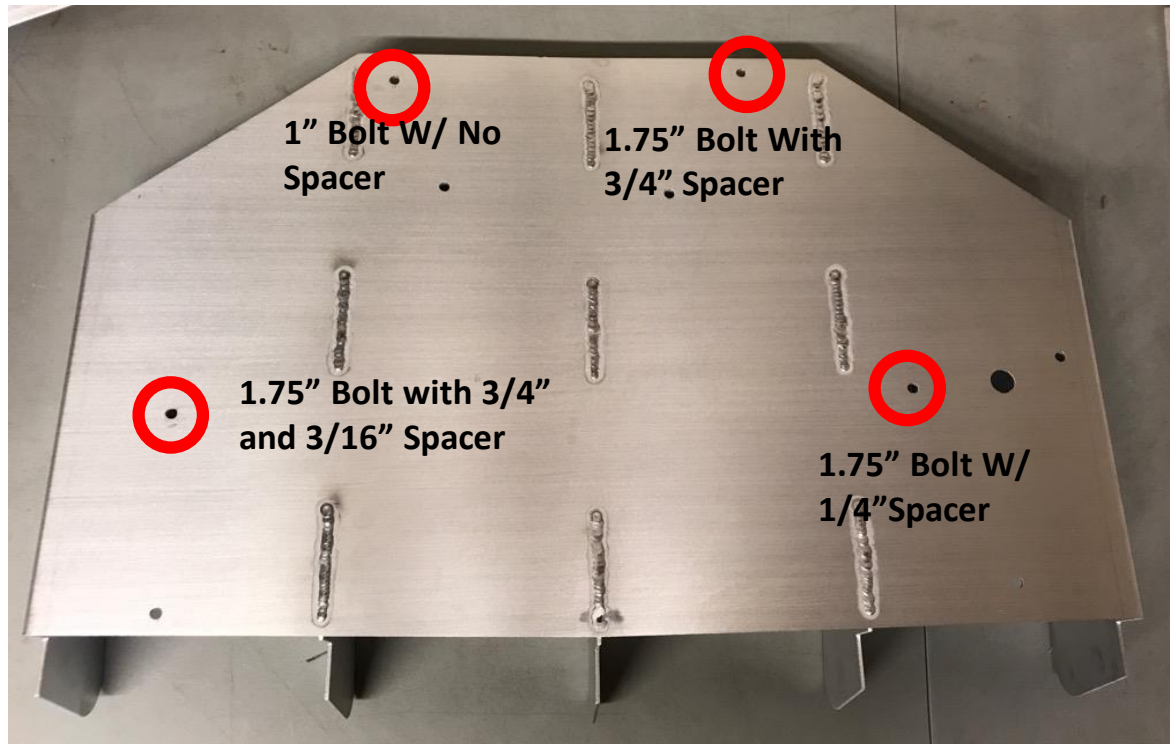

Spacer and Location Guide  
Dodge Magnum 2005-2008 – All Trim Levels

